

Trichloroethylene decomposition by the nonthermal plasma Combined with manganese-dioxide supported alumina

T. Oda, H. Kuramochi and R. Ono
Dept. Electr. Eng., The University of Tokyo
7-3-1 Hongo, Bunkyo-ku, Tokyo, 113-8656, Japan

Abstract— Dilute trichloroethylene (TCE) decomposition in a dielectric barrier discharge reactor combined with catalyst was investigated. Three types of the plasma process concerning with the catalyst were compared. In this experiment, the plasma process where the catalyst settled at the down flow of the reactor (named as Outer Catalyst in the paper) suggests the best. On the other hand, TCE decomposition by Inner Catalyst process (catalyst is in the plasma reactor) is worse than that by the non-thermal plasma process without the catalyst.

Keywords—nonthermal plasma, TCE decomposition, manganese-dioxide, wave-form dependence

I. INTRODUCTION

Many researchers have reported the decomposition of various toxic gasses in the air or in the combustion flue gas by using the non-thermal plasma. Late Prof. Masuda suggested the usage of the strong discharge for various chemical processes by using the pulse technology. His group reported the NO_x removal by the pulse plasma [1] and his younger follower Prof. Mizuno applied that technology to remove SO_x and NO_x in Florida [2]. Profs. Chang and Yamamoto reviewed the future possibility of that non-thermal plasma for environmental protection technology [3] and many successive reports were published [4]-[6]. Yamamoto *et al* at RTI (Research Triangle Institute) reported the decomposition of VOCs (volatile organic compounds) including 1000ppm CFC-113 in the air which was very difficult to decompose by the plasma and they succeeded in decomposing CFC-113 only by the batch system (gas flow is stopped and so many discharge pulses are repeated. Maximum TCE decomposition efficiency is only 70 % [7]. The authors succeeded in decomposing more than 99% of 1000ppm CFC-113 in the air [8] by using the ceramic surface discharge reactor. At present, many reports have been published by many authors [9]-[11]. Now how to improve the energy efficiency and to reducing toxic byproducts are main research targets. The authors are focused on the dilute trichloroethylene (TCE: CCl₂=CClH; mass number 131.39) decomposition to compare the all data observed by the authors to judge the effectiveness of the new process. Main byproducts are trichloroacetaldehyde (TCAA: CCl₃COH), dichloroacetylchloride (DCAC: CCl₂HCOCl), carbon oxide (CO and CO₂), phosgene (COCl₂), chlorine (Cl₂) and water. If the plasma energy is sufficient, DCAC and TCAA are decomposed completely. Combination with the catalyst is very good process and the authors have

already tested vanadium oxide (V₂O₅), tungsten oxide (W₂O₃), titania (TiO₂), Na-doped zeorite, Cu-doped zeorite, alumina, and so on [12]. The non-thermal plasma in air generates much amount of ozone at the TCE decomposition process. When the TCE- contaminated air is mixed with pure plasma- processed (ozone-rich) air and is introduced into GCMS, some part of the TCE is decomposed at the GCMS inlet where temperature is 250°C and the ozone decomposes. Einaga *et al* [10] reported ozone decomposition and VOCs decomposition by using the manganese-dioxide. The authors also used that manganese-dioxide supported catalyst and found that decompose TCE very well [13]. Following that work, some parameters are examined again and new effects of the MnO₂-supported alumina just after the plasma region were also investigated in this paper.

II. EXPERIMENT

A. Experimental System

Figure 1 shows the schematic diagram of the experiment system which is the same as that reported in previous paper [13,15]. The balance gas in this experiment is the synthesized dry air (Nitrogen: Oxygen = 4: 1) in which trichloroethylene (TCE; CCl₂=CCLH; mass number 131.39) liquid is injected through the micro-flow pump (ESP-33, EICOM Co.). The initial concentration of TCE is adjusted to 100ppm at the flow rate of 1L/min. As TCE vapor pressure is low at the room temperature, the TCE is heated up for easy evaporation.

B. Atmospheric Non-thermal Plasma Reactor

The plasma reactor is the coaxially cylindrical reactor with a stainless-steel bolt discharge electrode as shown in Figure 2. The inner diameter of a quartz (dielectric barrier tube) tube is 16.8mm. The diameter of a discharge electrode is 16mm. The length of discharge

Corresponding author: Tetsuji Oda
e-mail address: oda@ee.t.u-tokyo.ac.jp

Received; August 15, 2007, Accepted; March 17, 2008

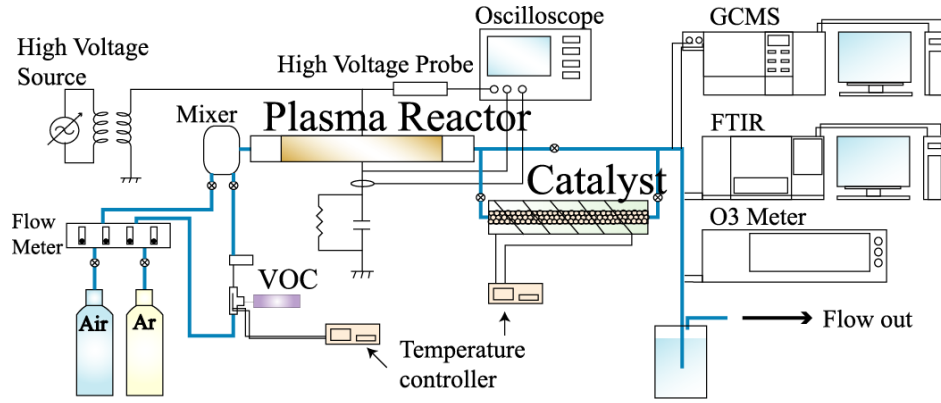

Fig. 1. Schematic diagram of experimental system.

region and the discharge gap are about 255mm long and 0.4mm wide, respectively. The volume of the discharge area is 5.26cm³. Fourier Transform Infrared Spectroscopy (FTIR; IRPrestige-21, Shimadzu Co.) with the multi-reflection long optical path gas cell, and Gas Chromatograph Mass Spectrometer (GCMS; QP5050A, Shimadzu Co.) are used for analyzing the decomposition byproducts. The high voltage power amplifier ($\pm 20\text{kV}$, $\pm 10\text{mA}$; Model 20-20C, TREK) with the function generator (WF1946, NF Corp.) is used to excite the plasma reactor.

The electric discharge power is measured by using the Lissajous' method as shown in Figure 3 (inner area multiplied with the frequency). The electric discharge power is also obtained by integrating of the voltage and the current products (1) for one or more cycles (multiplied with the frequency). However the voltage and the current waveforms which are shown in Fig. 4 contains so much high frequency components and integration must be done with a short times segment (nanoseconds order).

$$P[W] = \frac{1}{T} \int_0^T V_1(t) \times i(t) dt \dots \dots (1)$$

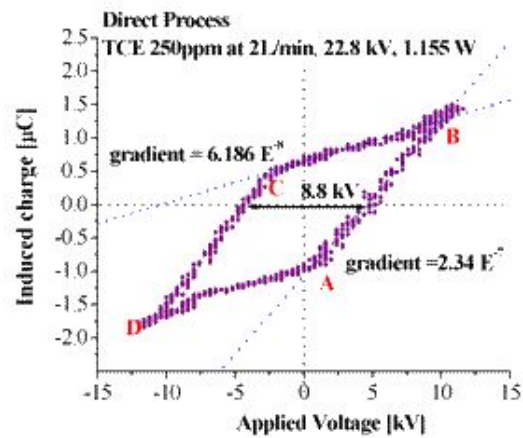

Fig. 3. V - Q Lissajous Waveform.

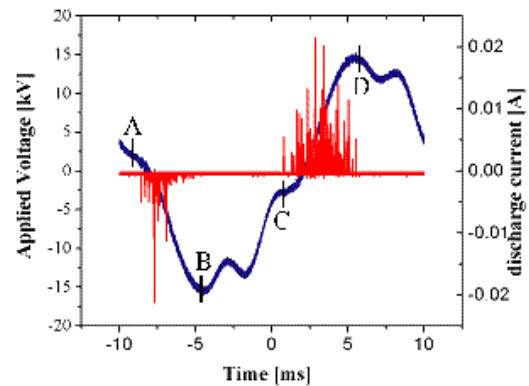

Fig. 4. Voltage - Current Waveform.

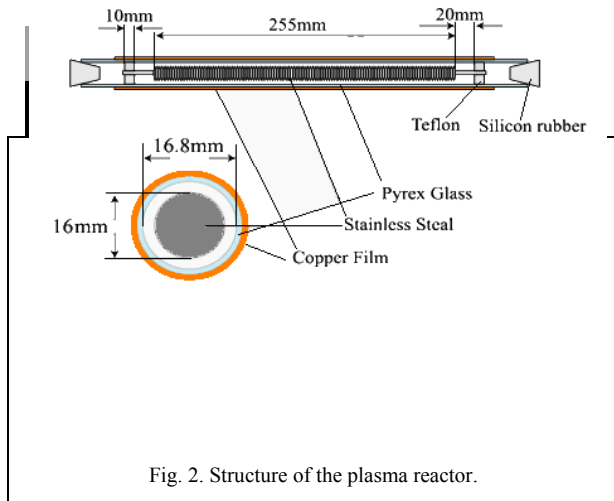

Fig. 2. Structure of the plasma reactor.

III. RESULTS AND DISCUSSION

A. Exciting Voltage Waveform Effects

(a) Frequency Dependence

TCE decomposition efficiency is strongly dependant on the plasma exciting frequency and the authors already reported that from 50Hz to 2kHz[3][4]. In the case of CFC-113 decomposition, high frequency plasma can decompose very well because high discharge power is necessary to decompose CFC. TCE decomposition

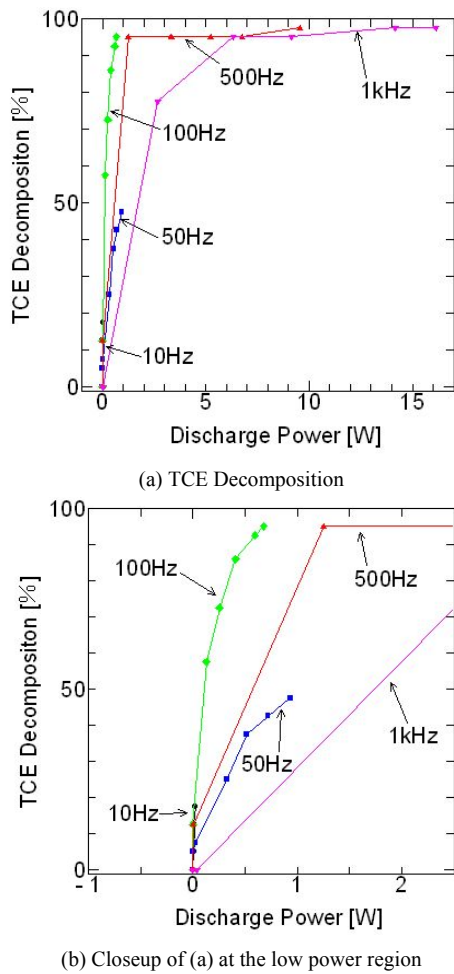

Fig. 5. TCE Decomposition for frequency.

efficiency is defined as eq. (2) where TCE and TCE_i are the TCE concentration after and before the plasma process in this experiment. Figure 5 (a) shows TCE decomposition efficiency versus the power consumption for different excitation frequency. Figure 5 (b) is the enlarged figure at the low power consumption area.

$$\text{TCE decomposition efficiency [\%]} = \left[1 - \frac{\text{TCE}}{\text{TCE}_i} \right] \times 100 \dots \dots \dots (2)$$

As the discharge power is roughly proportional with the frequency, the TCE decomposition efficiency is rather small for low frequency plasma because of the shortage of the injected discharge power. the low frequency excitation. The power source output voltage is

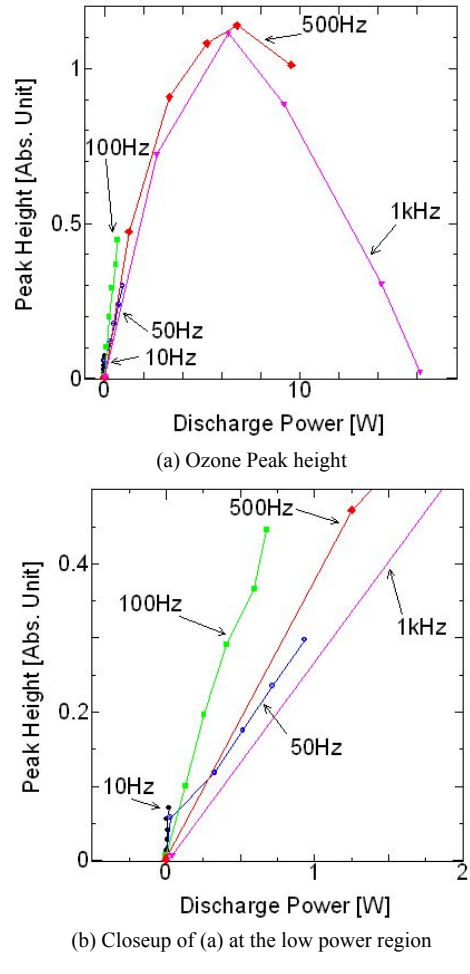

Fig. 6. Ozone Peak height for frequency.

limited and high discharge power cannot be injected into the plasma at the low frequency plasma. We cannot discuss more details at present. In general, Fig.5 is in good agreement with the previous works [16].

The ozone generation by the same plasma reactor is also shown in Fig.6 where the horizontal axis is the discharge energy consumption. That result is also in good agreement with the previous work [16].

(b) *Waveform Effects*

For the good plasma generation, dV/dt should be large. The plasma generation performance for different exciting high voltage waveforms is measured. TCE decomposition efficiency and ozone generation versus discharge power consumption for four different waveforms are shown in Figs.7 and 8. For both ozone generation and TCE decomposition, square wave plasma

TABLE I
MAIN BYPRODUCTS CHARACTERISTICS.

Name	Chlorine	Dichloroacetylchloride	Trichloroacetaldehyde	Phosgene
Molecular Formula	Cl ₂	CHCl ₂ CClO	CCl ₃ CHO	CCl ₂ O
Molecular Weight	70.91	147.4	147.4	98.92
Toxicity	Apparatus respiratorius Damage Heart Disease apoplexia cerebri	lachrymator Causticity for Apparatus Fatality by Suction	Excitement for Apparatus Influence for central nerve Blackout	Poison Gas Apparatus respiratorius Damage Chemical Weapon

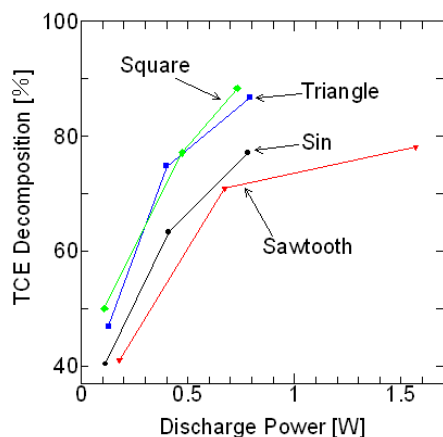

Fig. 7. TCE Decomposition for waveform.

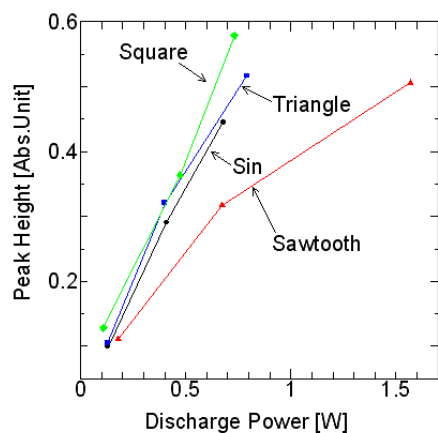

Fig. 8. Ozone peak height for waveform.

is the most efficient reaction among 4 plasmas. The sharp increase of the applied voltage between the two electrodes may contribute the streamer formation very well.

B. Plasma Process Combined with Catalysts

(a) Integral Disposal of Reactor with Catalysts

Many byproducts are generated during the nonthermal plasma process for the dilute TCE. They are shown in Table 1 observed in previous works [5-7]. The energy efficiency of the nonthermal plasma decomposition for various VOCs (which is named as "Direct Process" [4]) is not so good compared with other conventional VOC removal process. The authors have been engaged in optimizing the plasma process parameters; such as flow rates, voltage waveform (in previous section, in this paper), reactor configuration [12-16], etc. To improve that energy efficiency, many researchers have challenged to combine the catalyst process. The authors also tested to use various kinds of catalysts, such as TiO_2 , V_2O_5 , W_3O_4 , etc [14]. During those works, the authors also found that the new process, named as "Indirect Process", can decompose TCE pretty well. Sometimes, the energy efficiency for Indirect Process is better than that for Direct Process. In this

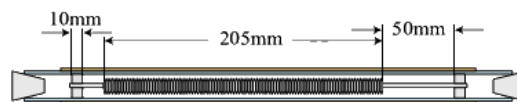

Fig. 9. Customized Plasma Reactor.

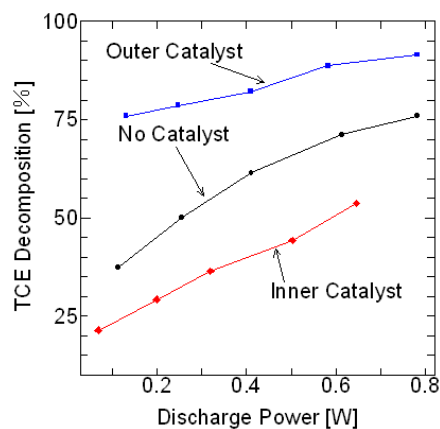

Fig. 10. TCE Decomposition for catalyst type.

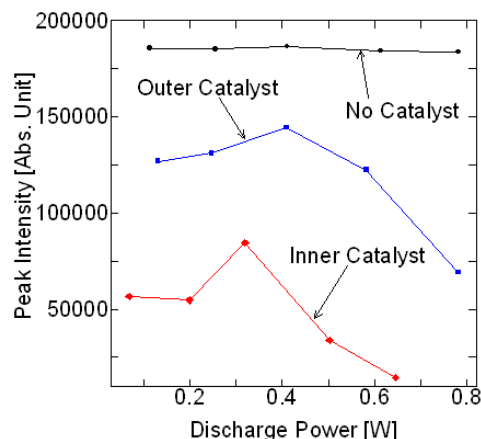

Fig. 11. Ozone peak height for catalyst type.

process, only the pure air passes through the plasma reactor. That decomposition efficiency. For that test, a new reactor as shown in Fig.9 is fabricated where (back part of the discharge electrode is changed to a thin pipe (no discharge occurs)). In that area, 250mg manganese-dioxide supported aluminum oxide (MnO_2 : 1.0wt%) is filled. This process is named as "Inner Catalyst". Figure 10 shows TCE decomposition versus the discharge energy. Figure 11 also shows the ozone generation versus discharge energy, separately. In this experiment, 100Hz sinusoidal waveform high voltage is applied to the plasma reactor. Byproducts analysis is also shown in Figures 12 - 16 for phosgene (Fig.12), trichloroacetaldehyde (TCAA: CCl_3CHO Fig.13), dichloroacetaldehyde (fig.14), chlorine (Fig.15), and CO_2 (Fig.16). Concerning with the TCE decomposition, TCE decomposition for Inner Catalyst is worse than that of Direct Plasma process which has never estimated before this experiment. Some miscellaneous energy loss might be added. This tendency is very common for all other data shown in other figures. However, byproducts

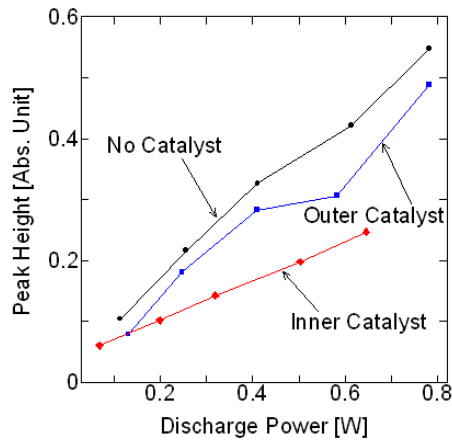

Fig. 12. Phosgene for catalyst type.

Fig. 15. Cl₂ peak intensity for catalyst type.

Fig. 13. Trichloroacetaldehyde for catalyst type.

Fig. 16. CO₂ peak intensity for catalyst type.

Fig. 14. Dichloroacetylchloride for catalyst type.

generated by the Direct Process (No Catalyst) are much larger than byproducts produced by the Outer Catalyst process indicating the superiority of the Outer Catalyst process. As the ozone generated by the plasma reactor may be decomposed on the manganese-dioxide supported catalyst and may produce activated atomic oxygen radical ($O_3 \rightarrow O_2 + O^*$) which might decompose TCE and

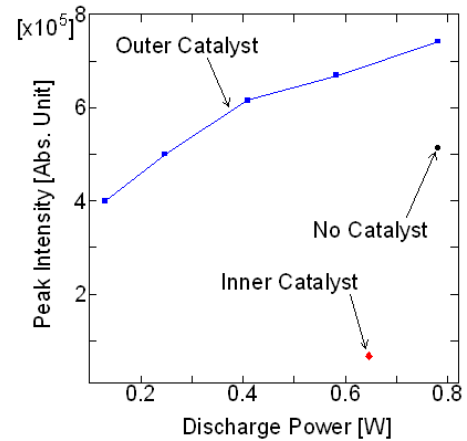
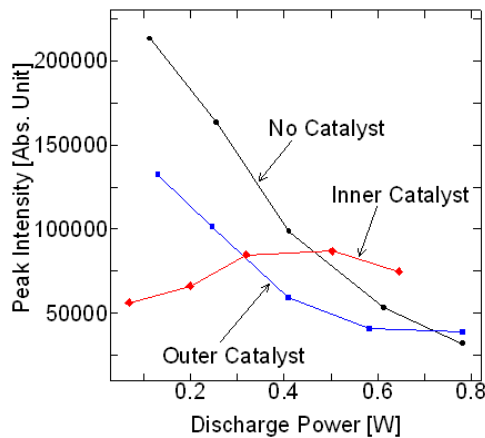
other byproducts. Production of toxic phosgene is very small at the discharge energy of 0.65W for Inner Catalyst process. That reason is not yet clear but will be discussed more in near future. Production of DCAC for the Outer Catalyst process is very small and also pretty small for Inner Catalyst process suggesting the reduction of DCAC is done on the catalyst surface with the ozone. The production of DCAC is also proportional with the plasma discharge power indicating that DCAC is produced in the plasma process. On the other hand production of TCAA is very large at small discharge power for No Catalyst and Outer Catalyst and TCAA generation decreases drastically with the increase of power. Generation of carbon dioxide increases monotonically with increase of the discharge power. That tendency (CO₂ increase gradient versus the power) is the strongest for No Catalyst process. It is interesting that the carbon dioxide concentration for Outer Catalyst process at rather small discharge power is very small. If TCE is fully decomposed, CO₂). The extrapolation of CO₂ versus power to zero power, only the catalyst can change TCE to carbon oxide which is unbelievable.

IV. CONCLUSIONS

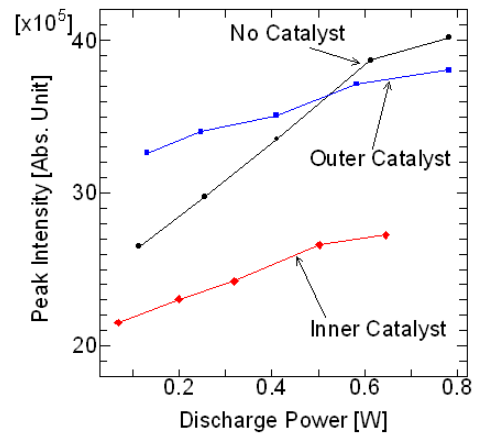
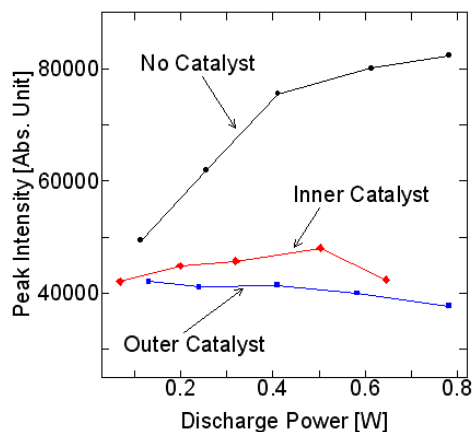
Several experiments concerning to the dilute TCE decomposition in the air by the nonthermal plasma were performed and following results were obtained.

1. Optimization of plasma exciting frequency: TCE decomposition efficiency is the best at 100Hz excitation frequency which is a little bit higher than that in previous work. The optimal frequency should be strongly dependant on the reactor configuration and other many parameters.
2. Waveform effect: As very quick voltage change may generate desirable plasma, TCE decomposition by the squarewave or triangle voltage excitation is very well. However, it is not yet clear why sawtooth waveform excited plasma cannot decompose TCE efficiently.
3. Combination with the catalyst: Three models, i No Catalyst, ii Outer Catalyst (catalyst is at the down flow), iii Inner Catalyst (catalyst is just after the plasma in the same reactor), were compared. In this experiment, "Outer Catalyst" suggests the best TCE decomposition efficiency but the energy efficiency of TCE decomposition process by Inner Catalyst is very bad (worse than that by the Direct Process). The clear explanation of this matter is not yet done. One possibility is that energy consumption in the catalyst area is large which does not affect the TCE decomposition.

ACKNOWLEDGEMENT

This work is partially supported by Scientific Grant in aid from the Ministry of Education, Culture, Science and Technology. The authors also thank Mr. Koichi Ono who did this work before and also strongly appreciate Drs. Ogata and Kim for their help to make the new catalyst.

REFERENCES

- [1] S.Masuda, H.Nakano, "Control of NOx by positive and negative pulsed corona discharge", Conference Records of the IEEE/IAS Annual Meeting, Denver, CO, pp.1173-1182 (1986)
- [2] A.Mizuno, J.S. Clements, R.H. Davis, "A device for the removal of sulfur dioxide from exhaust gas by pulsed energization of free electrons", Conference Records of the IEEE/IAS Annual Meeting, Denver, CO, pp.1015-1020 (1984)
- [3] J.S.Chang, P.A.Lawless and T.Yamamoto: "Corona Discharge Processes", IEEE Trans. Plasma Sci., 19 pp.1152-66 (1991)
- [4] T.Ohkukubo, S.Kanazama, Y.Nomoto, T.Adachi, K.Yan, J.S.Chang, "Effect of corona discharge modes on removal of NOx from air streams in a corona radical shower system", Proceedings of the second Non-Thermal Plasma Technology and Gaseous Pollution of Control, Salvador, pp70-73 (1997)
- [5] K.Shimizu and T.Oda, "Nitrogen Oxides Removal by Using Plate Type Reactor Combined with Catalysts", J.adv.Oxid.Technol., vol.5, pp.217-222 (2002)
- [6] Y.Yoshioka, K.Sano and K.Teshima, "NOx removal from Diesel Engine Exhaust by Ozone Injection Method", J.Adv. Oxid. Technol., vol.6, pp.143-149 (2003)
- [7] T.Yamamoto, K.Ramanathan, P.A.Lawless, D.S.Ensor, J.R.Newsome, "Control of volatile organic compounds by an AC energized ferroelectric pellet reactor and a pulsed corona reactor", IEEE Trans. Ind. Appl. 28, pp.528-534 (1992)
- [8] T.Oda, T.Takahashi, H.Nakano, S.Masuda, "Decomposition of fluorocarbon gaseous contaminants by surface discharge-induced plasma chemical processing", IEEE Trans. Ind. Appl. 29 pp.787-792 (1993)
- [9] A.Ogata, N.Shintani, K.Mizuno, S.Kushiyaama, "Effect of water on benzene decomposition using packed-bed plasma reactor", Proceedings of the Asia-Pacific Workshop on Advances in Oxidation Technology, Tsukuba, pp.91-96 (1998)
- [10] H.Einaga, T.Ibusuki and S.Futamura: "Performance Evaluation of Hybrid Systems Comprising Silent Discharge Plasma and Catalysts for VOC Control", Conf.Rec. IEEE Trans. Ind.Appl, vol.37, pp1476-1482 (2000)
- [11] K.Urushima, T.Misaka, T.Ito and J.S.Chang, "Destruction of Volatile Organic Compounds in Air by a Superimposed Barrier Discharge Plasma Reactor and Activated Carbon Filter Hybrid System", J.Adv.Oxid.Technol., vol.5,pp.135-140 (2002)
- [12] T.Oda, K.Yamaji and T.Takahashi, "Decomposition of Dilute Trichloroethylene by Nonthermal Plasma Processing – Catalyst and Ozone Effect", IEEE Trans.Ind. Appl., vol.40 pp.430-436 (2004)
- [13] T.Oda, K.Ono, and R.Ono.: "Dilute TCE decomposition by the nonthermal plasma combined with MnO2-supported alumina," IEER Trans.Fundamentals and Materials, vol.127, no.3, pp.145-150 (2007)
- [14] T.Oda, T.Takahashi and K.Yamaji, "TCE Decomposition by the Nonthermal Plasma Process Concerning Ozone Effect", IEEE Trans.Ind.Appl., vol.40,pp.1249-1256 (2004)
- [15] S. B. Han, T. Oda, and R. Ono: "Improvement of the energy efficiency in the decomposition of dilute trichloroethylene by the barrier discharge plasma process," IEEE Trans. Ind. Appl., Vol. 41, No. 5, pp. 1343-1349 (2005)
- [16] T.Oda, T.Takahashi and S.Kohzuma, "Decomposition of dilute trichloroethylene by using Nonthermal plasma processing-frequency and catalyst effects" IEEE Trans. Ind. Appl. Vol.37, No.4, pp.965-970, (2001)