

Contribution to the electro-thermal behavior study of a porous dielectric barrier plasma reactor under direct current

Fatiha Tounsi^{1,2}, Rabah Ouiddir³, Abdelber Bendaoud^{1,*}, Mohamed Miloudi⁴,
Houcine Miloudi¹

¹APELEC Laboratory, Department of Electrical Engineering,
Djillali Liabes University of Sidi Bel Abbes, Algeria

²University of Mascara, Algeria

³Mohamed Boudiaf University (USTO) Oran, Algeria

⁴University of Relizane, Algeria

* Corresponding author: babelber@gmail.com (Abdelber Bendaoud)

Received: 1 February 2025

Revised: 17 July 2025

Accepted: 16 October 2025

Published online: 24 October 2025

Abstract

Nonthermal plasma generated by atmospheric pressure electrical discharges has garnered increasing scientific and industrial interest due to its numerous technological applications. Dielectric barrier discharges (DBD) are particularly well-recognized and widely used for various applications, ranging from surface sterilization to material modification. However, they present certain operational challenges, primarily due to their relatively high energy consumption, especially when operating under alternating voltage. This energy cost represents a major issue for industries seeking to optimize the energy efficiency of these systems. Another challenge lies in the thermal management of DBDs: indeed, the thermal nature of the discharges requires precise regulation of the dielectric barrier's temperature to prevent the risk of thermal shocks, which can damage the device. To achieve this, current systems often require the integration of an auxiliary cooling system that operates continuously, further increasing energy consumption. This article contributes to addressing this issue by conducting an experimental electro-thermal behavior study of a porous dielectric barrier plasma reactor. The main innovation of this approach lies in the reactor's design, which allows, on the one hand, operation under direct voltage. This choice enables significant energy optimization while minimizing the risk of arcing, which is a major advantage for the durability and safety of industrial systems. On the other hand, the porous nature of the dielectric barrier provides a natural solution for dissipating the heat generated by the active electrode, as the thermal flux can be effectively evacuated through the material's pores. The experimental results demonstrate notable discharge stability over time, confirming the potential of this configuration for industrial applications. In addition to demonstrating improved thermal management, this solution offers promising prospects for enhancing energy efficiency and reducing operational costs associated with dielectric barrier discharge systems in industrial settings.

Keywords: Nonthermal plasma, dielectric barrier discharges (DBD), energy efficiency, thermal management, porous dielectric barrier.

1. Introduction

The dielectric barrier discharge (DBD), also known as the "silent discharge," is a type of nonthermal, non-equilibrium plasma. This discharge was discovered in 1857 by Werner von Siemens during his work on ozone generation and has since found numerous applications across various scientific and industrial fields [1, 2]. The DBD systems consist mostly of two parallel plates or two coaxial cylinders, and they are characterized by presence of a dielectric layer covering at least the internal surface of one of the two discharge electrodes or both [3]. DBDs are currently generating significant interest due to their wide range of applications. They are widely used in various industrial sectors, such as ozone generation [4], surface treatment [5], inactivation of

microorganisms [6], thin-film deposition [7], pulsed-electric field, and sterilization [8], and the decontamination of toxic gases [9].

Over the past decades, DBDs have also found applications in emerging technologies, including UV excimer lamps, plasma display panels, surface modification for specific materials, and biomedical applications [10], such as the sterilization of living tissues, inactivation of bacteria, and dentistry [3]. The portable DBD plasma-based sterilization system was developed to combat the Covid-19 pandemic [11], as well as for treating skin diseases, chronic wounds, cosmetics [12]. As well as various applications in the field of environmental protection (pollution control, destruction of hazardous compounds) [13].

High-voltage nanosecond discharges, which are created in gas bubbles inside the volume of water or in a gas environment near the water surface, have good prospects for wide industrial use in disinfection, wastewater treatment [14]. Thus, plasmas are used across various structural and technological systems, scientific research, and more [15]. However, despite their many advantages, DBDs face technical challenges. One of the main challenges lies in the fragility of dielectric barriers, which can reduce system robustness. Additionally, the thermal dissipation generated by the electrical discharge often requires a continuous cooling system, increasing the overall operating and maintenance costs, especially for installations running continuously. Low-temperature plasmas jets are unique plasma sources capable of delivering plasma outside of the confinement of electrodes and away from gas enclosures/chambers. With these jets plasma can be easily delivered to a target located at some distance from the plasma generation region. Various power driving methods have been used to ignite and sustain low temperature plasma jets. These include direct current (DC), pulsed DC, Radio Frequency (RF), and microwave power. In particular, low temperature plasma jets that are generated at atmospheric pressure are playing an ever increasing role in many plasma processing applications, including surface treatment and in biomedicine [16].

DBD plasma applications also extend to engineering fields, including flow control and ice mitigation [17]. Typical materials to create dielectric barriers in DBDs are glass, quartz, ceramics, and polymers [18]. Fig. 1 summarizes some selected milestones of DBD research, [19, 25].

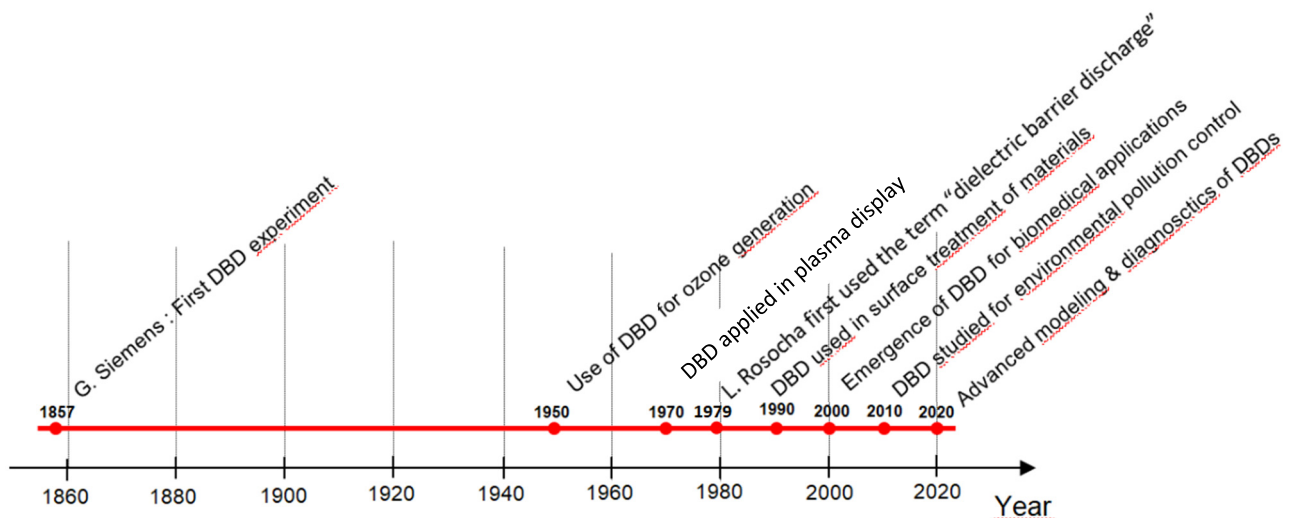

Fig. 1. Selected milestones of research on dielectric barrier discharges (DBD).

The work presented in this article primarily aims to improve the electro-thermal behavior performance of a DBD reactor by seeking to optimize both energy efficiency and the durability of the dielectric barrier. Indeed, one of the main objectives of a plasma reactor is to provide, in a controlled manner, the required amount of charges or activated molecules to meet the specific requirements of the intended application, while minimizing energy consumption costs and avoiding degradation of the dielectric barrier. This dual requirement presents a significant technical challenge in the design of DBD reactors, where the fragility of the dielectric barrier and thermal stresses can limit overall performance. In this spirit, we conducted a thorough experimental study on a new plasma reactor with a porous dielectric barrier (PDB) operating under direct current.

The design of this reactor is innovative due to the integration of a porous dielectric barrier, which offers two major advantages: on one hand, it allows operation under direct current, thereby optimizing energy

efficiency and avoiding the costs associated with alternative systems; on the other hand, the porous structure of the barrier facilitates thermal dissipation by allowing a steady heat flow through the pores, which reduces the risk of overheating and preserves the integrity of the reactor. This configuration aims not only to stabilize the generated plasma but also to extend the reactor's lifespan by limiting the impact of thermal stresses. The results of this experimental study provide a promising perspective for the development of more efficient and robust DBD reactors, suited for industrial applications requiring continuous and reliable operation.

2. Experimental setup and materials

The DBD reactor used in this study, illustrated in Fig. 2, is designed according to configurations similar to those commonly employed in research on nonthermal plasmas.

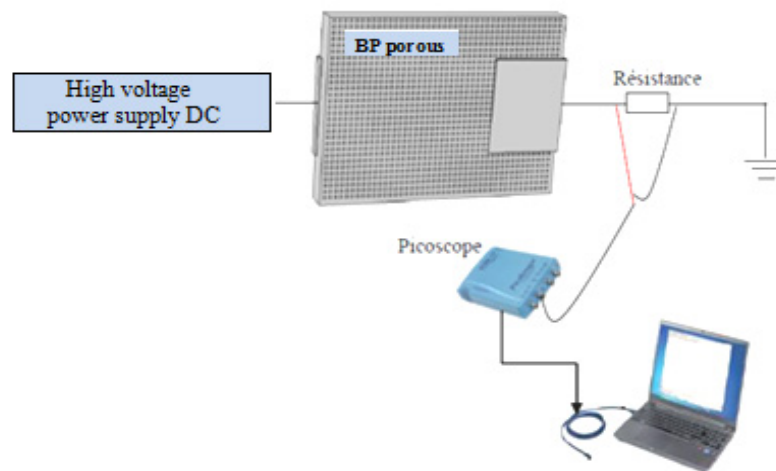

Fig. 2. Schematic of the experimental setup implemented.

This device consists of two asymmetric electrodes: an active electrode and a passive electrode separated by a porous ceramic dielectric barrier (Fig. 3).

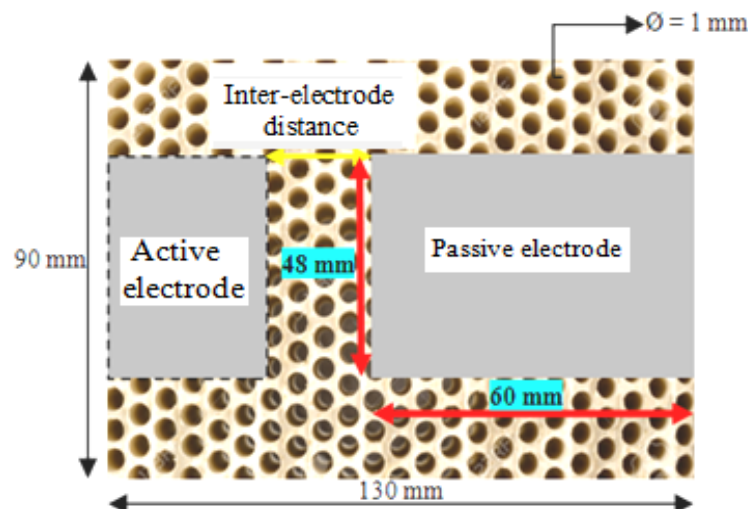

Fig. 3. Dimensions of the porous dielectric used.

The distinctive feature of this dielectric lies in its porous structure, which has uniformly sized pores with a diameter of 1 mm, evenly distributed over a surface area of $130 \times 90 \text{ mm}^2$, allowing for efficient thermal dissipation. The dielectric barrier itself has a thickness of 10 mm, ensuring optimal insulation and mechanical stability under high voltage conditions.

The plasma is generated by applying a high negative DC voltage to the active electrode, which is made of adhesive aluminum. The other electrode, referred to as the passive electrode, is connected to the ground, ensuring the safety and stability of the system. The voltage required to achieve the discharge is supplied by a high-voltage generator from Spellman, model SL-60, capable of delivering a maximum voltage of $U_{\max} = 40$ kV and a maximum current of $I_{\max} = 7.5$ mA. This generator allows for precise control of the voltage and current parameters, which are essential for maintaining a stable plasma and avoiding the risks of overload or damage to the dielectric barrier.

The configuration of this experimental setup was specifically chosen to optimize plasma generation while ensuring effective thermal dissipation through the porous structure of the dielectric barrier. This system offers an innovative solution for applications requiring stable and nonthermal plasma with optimized energy efficiency. In the case of a sinusoidal power supply, the energy injected into a DBD reactor is generally measured using Lissajous cycles, which consist of plotting the charge passing through the gas as a function of the voltage applied across the reactor. This method provides precise information on the dynamics of the electric discharge in a plasma powered by alternating current.

In our experimental setup, however, the reactor operates in continuous mode, and the discharge current is measured by evaluating the instantaneous voltage across a 528Ω resistor placed in series with the ground electrode. This resistor converts the discharge current into a measurable voltage, which is then visualized using a probe connected to channel A of a PicoScope oscilloscope (model 3207B, with a bandwidth of 250 MHz and a sampling rate of 1 Gs s^{-1}). This configuration ensures real-time monitoring of current variations in the reactor, providing crucial information about the stability and intensity of the discharge.

The main objective of this study is to measure the temperature distribution generated by the porous dielectric barrier reactor (PDB) in the absence of external air or gas flow. This allows for a precise evaluation of the reactor's thermal dissipation capability and an investigation of how heat propagates within the dielectric barrier depending on the discharge characteristics. To achieve this, complementary electrical and thermal diagnostics were used. A parametric study was also conducted, varying several electrical parameters (such as voltage and current) as well as the geometric characteristics of the reactor (such as the thickness and porosity of the dielectric barrier). This approach allows for a better understanding of the physical mechanisms linking the discharge to heat production and their impact on the surface condition of the dielectric barrier, providing insights for optimizing the design of porous DBD reactors and enhancing their durability.

3. Advantages of the Porous Ceramic Plate

The selection of a porous ceramic dielectric for our DC-driven surface discharge reactor was a deliberate design choice, offering several key advantages over nonporous alternatives. While this study didn't conduct a direct, dedicated experimental comparison between porous and nonporous ceramics—a task often beyond the scope of a single investigation—the inherent properties of porous dielectrics are well-established in the literature and fundamentally support the enhanced performance observed in our reactor.

Firstly, the porous structure significantly boosts gas permeability. This allows reactive species generated by the plasma to penetrate deeper into the dielectric material, creating a much larger effective surface area for interaction. This heightened interaction is vital for efficient plasma-chemical reactions and directly facilitates the improved formation and transport of ionic wind, which in turn optimizes the electric field distribution near the surface.

Furthermore, the interconnected pores act as numerous micro-channels, locally intensifying the electric field and guiding charge propagation. This feature is especially beneficial for initiating and sustaining stable streamer formation under DC excitation, particularly in low-conductivity gases like air and at atmospheric pressure, where high field intensities are crucial. The ability of our porous reactor to consistently maintain a stable, uniform corona discharge at higher current levels without transitioning to arcing, as evidenced in our Results (Section 4), implicitly highlights the positive influence of these micro-channels on discharge stability and current density.

Indeed, prior research by [20] and [21] consistently demonstrates that porous configurations lead to improved generation of reactive oxygen and nitrogen species (ROS/RNS) due to their increased surface area and favorable dielectric constant gradients at the gas-dielectric interface. These documented advantages are critical for the efficiency of plasma reactors in applications like air treatment.

Finally, the porous structure also positively impacts the reactor's thermal management. Heat generated during the discharge is more uniformly dissipated throughout the interconnected pore network, preventing localized overheating. This uniform thermal distribution contributes directly to the long-term stability and consistent operation of the system, minimizing the risk of thermal runaway and ensuring robust performance. In summary, the combination of these well-understood properties of porous ceramics provides strong justification for their use in our reactor design, and these properties are reflected in the superior electro-thermal performance presented in Section 4.

4. Results and discussion

4.1 Measurement and visualization of discharge current

A DBD must necessarily be powered by a periodic supply; otherwise, it extinguishes. This is because when the discharge occurs, the charges it carries deposit on the surface and screen the external field [22].

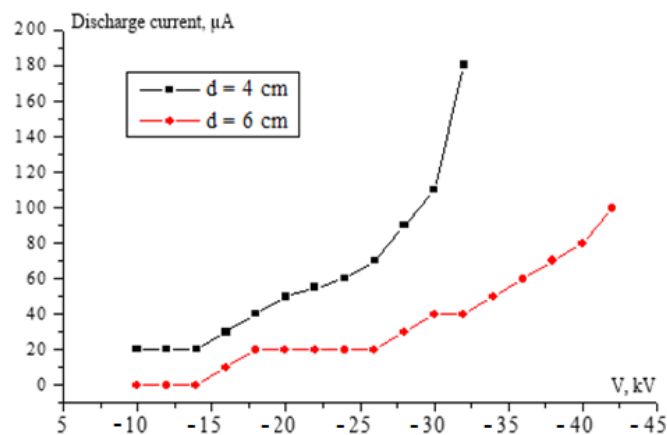

Fig. 4. Characteristic $I(U)$ as a function of inter-electrode distance (in the presence of the porous DB) under negative DC voltage.

The accumulation of charge on the dielectric barrier gradually reduces the electric field in the inter-electrode space, leading to a rapid extinction of the plasma filaments. This phenomenon explains the extremely short lifespan of the filaments in a dielectric barrier discharge (DBD) reactor, as it is directly related to the time required for the electrons to reach the surface of the dielectric. Once the charges are adsorbed on the barrier, they do not diffuse across the surface and can remain stable for several minutes or even hours, unless an external phenomenon intervenes to recombine them. In the case of a porous dielectric barrier, the observed phenomena differ significantly. For example, at an inter-electrode distance of $d = 6$ cm (Fig. 4), it can be observed that the current is limited for voltages below -26 kV. However, beyond this value, the current increases proportionally without the discharge extinguishing, which can be explained by the fact that the external electric field becomes dominant over the field attenuated by the charge deposition. Furthermore, the discharge limiting effect disappears when the distance between the two electrodes is reduced, as in the case where the spacing is 4 cm. This reduction in distance can be achieved by increasing the length of the passive electrode, which alters the electric field configuration and, consequently, the discharge behavior.

The current measured in this configuration corresponds to the current flowing in the micro-discharges within the plasma. In addition to its continuous component, this current exhibits spikes whose amplitude can reach several milliamperes (Fig. 5). These spikes are more frequent when the potential difference between the electrodes increases (Fig. 6), indicating a rise in the activity of micro-discharges. These observations highlight the influence of inter-electrode distance and applied voltage parameters on the behavior of micro-discharges in a porous dielectric barrier, providing essential insights for controlling and optimizing the performance of DBD reactors in various industrial applications.

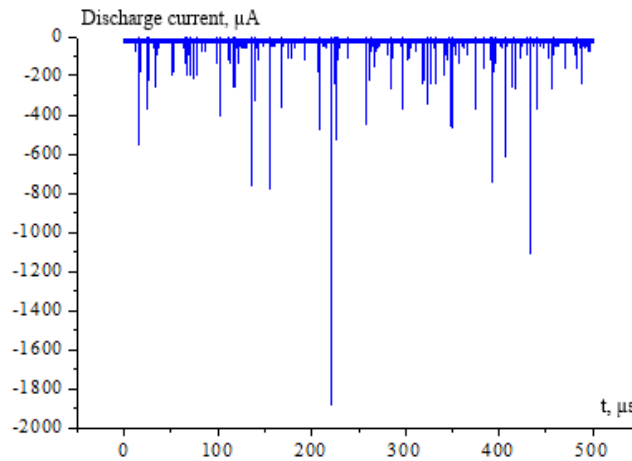

Fig. 5. Visualization of the corona discharge current for $U = -16$ kV and $d = 4$ cm.

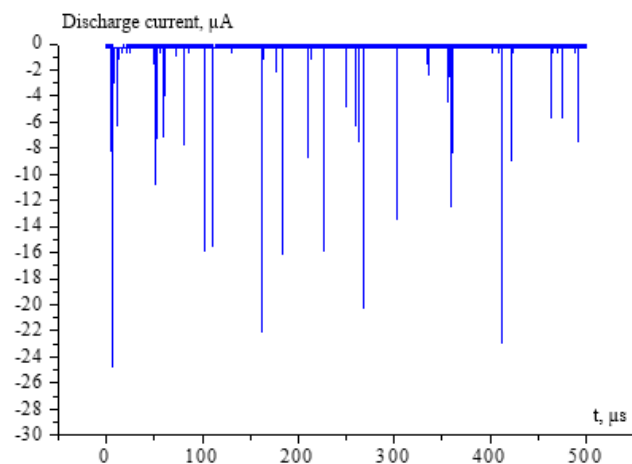

Fig. 6. Visualization of the corona discharge current for $U = -32$ kV and $d = 4$ cm.

4.2. Simulation of Temperature Distribution on the Surface of the Porous Dielectric Barrier

A numerical simulation was conducted using COMSOL Multiphysics to study the temperature distribution on the porous dielectric barrier (PDB) with an inter-electrode spacing of 6 cm and an applied voltage of -26 kV. The results of the simulation, presented in Fig. 7, show clearly that high-temperature areas are concentrated in the center of the space between the electrodes. This central thermal concentration is explained by the increased intensity of the electrical discharge in this region, where the electric field is the strongest.

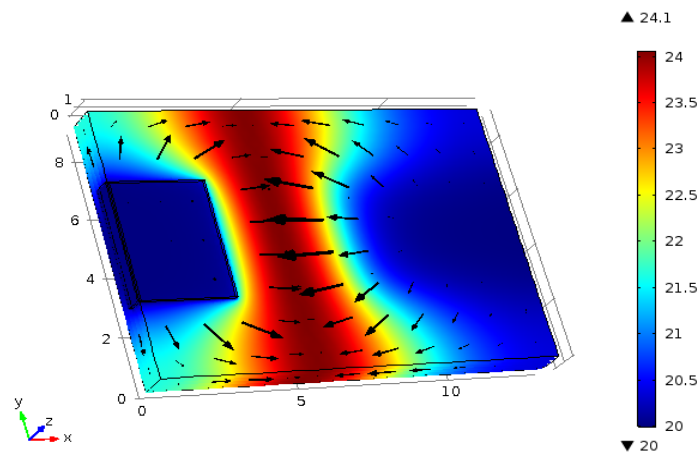

Fig. 7. Temperature distribution on the surface of the porous dielectric barrier (PDB) for $U = -26$ kV.

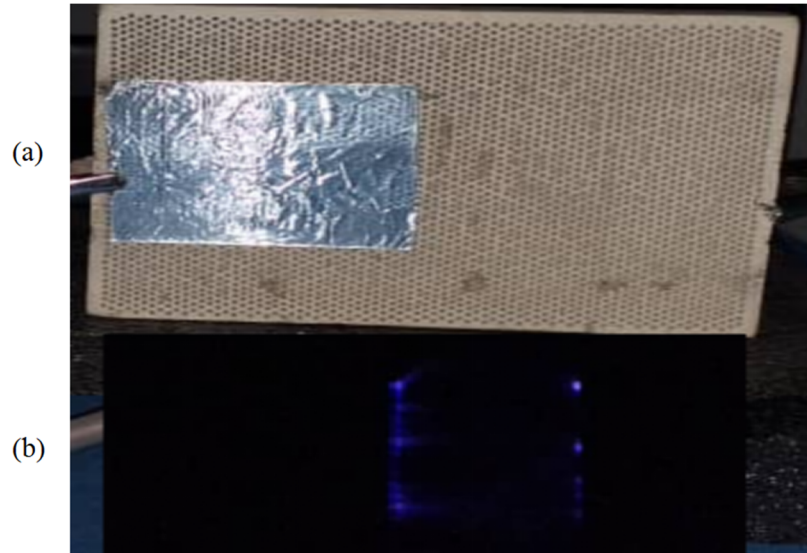

Fig. 8. Experimental visualization of the DBD discharge region: (a) Photo of the of the porous dielectric barrier (PDB); (b) Photo of the visible plasma taken during operation for $U = -26$ kV.

To support and validate the numerical findings, Fig. 8 presents experimental images of the DBD region. The upper image shows the physical arrangement of the electrodes and the PDB, while the lower image captures the plasma glow during operation, taken using a camera. It is clearly observed that the plasma emission is also centered between the electrodes, forming a luminous region that coincides spatially with the high-temperature area observed in the simulation. This visual agreement between the thermal map (Fig. 7) and the plasma glow (Fig. 8) confirms that the central region is the most active in terms of discharge and energy concentration. Such correspondence strengthens the validity of the simulation results and provides useful insight into the correlation between plasma activity and thermal behavior in the PDB.

4.3 Experimental Validation

The surface temperature of the porous dielectric barrier (PDB) was measured with an inter-electrode distance of 4 cm. Temperature readings were taken instantaneously for various applied voltage levels, with a five-minute interval between each measurement to allow sufficient cooling of the electrodes and the PDB.

This procedure ensures that the starting temperature is close to 22.5 °C for each measurement, providing reproducible measurement conditions. Temperatures were recorded using a non-contact infrared thermometer (model DT-8806S), allowing for accurate measurement of the thermal distribution along the porous plate without direct thermal interference.

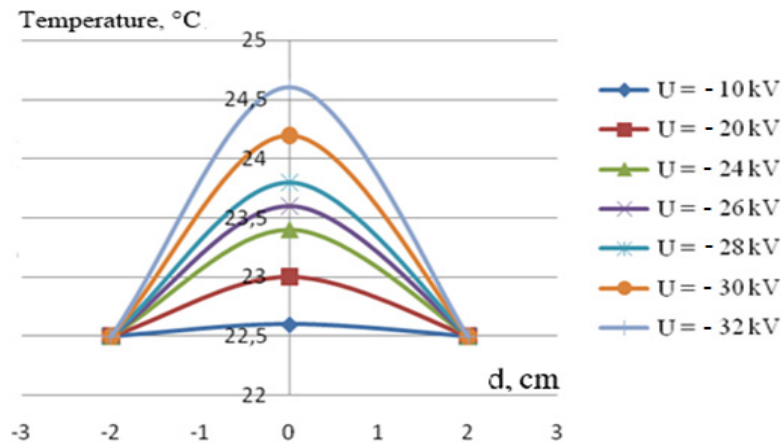

Fig. 9. Measured temperature distribution along the (PDB) for different voltage values, $d = 4$ cm.

Fig. 9 highlights that the temperature variation on the surface of the porous dielectric barrier (PDB) follows a Gaussian distribution, with temperature peaks recorded at the center of the porous plate. This is consistent with the simulation results shown in Fig. 7.

Fig. 10 provides a more detailed illustration of the temperature variation in the middle of the inter-electrode space, confirming the observed trend. This increase in temperature is likely due to the increased frequency of collisions between electrons and neutral gas molecules, influenced by the rising electric field. This phenomenon intensifies the thermal exchanges between the ambient air and the surface of the porous dielectric barrier (PDB), resulting in a notable increase in temperature in this region. The steady-state temperature can also be plotted as a function of the discharge current (Fig. 11). A temperature difference is recorded when changing from a current of 20 μA to 180 μA .

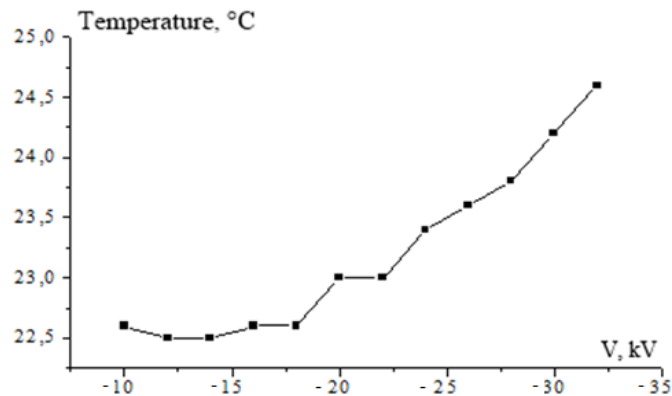

Fig. 10. Variation of the BDP temperature as a function of the applied voltage with negative polarity.

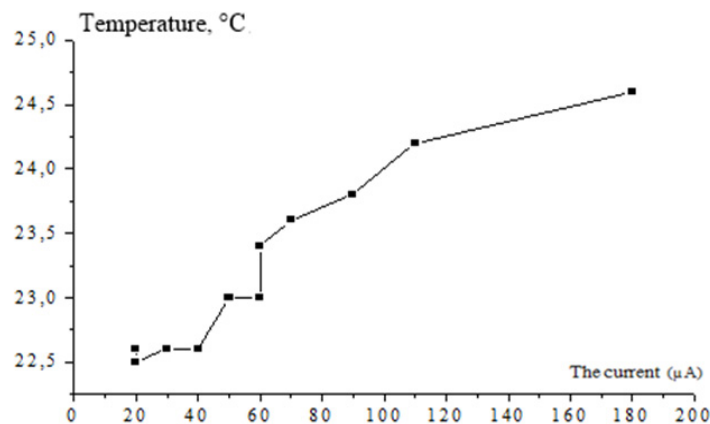

Fig. 11. Temperature of the porous dielectric barrier as a function of discharge current.

A dynamic measurement was conducted for two fixed voltages of 24 and 30 kV with $d = 4$ cm (Fig. 12). A sample is taken every minute, always at the center of the inter-electrode space. According to the results obtained, a stabilization of temperature is observed after three minutes of continuous operation, whether at a voltage of 24 kV or 30 kV. This is due to the pores in the BDP, which allow for self-cooling. In this case, the thermal exchange surface by convection (Wall-Air) is larger. This heat exchange regime becomes increasingly forced due to the electro-hydrodynamic (EHD) effect of the discharge [21–27], this explains the temperature limitation after more than ten minutes of reactor operation (Fig. 12). It should also be noted that the surface state of the DB remains intact, with no signs of degradation. Furthermore, the temperature measurement at the center of the inter-electrode space showed that heat transfer by conduction in the DB is negligible, due on one hand to the low thermal conductivity of the ceramic [7–8] and on the other hand to the presence of pores that allow for effective heat dissipation to the outside.

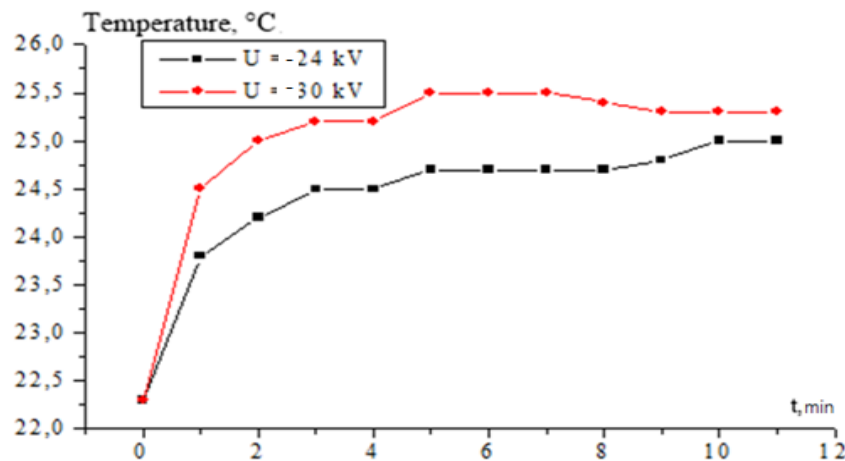

Fig. 12. Variation of temperature in dynamic regime.

4. Conclusion

The primary objective of this work was to demonstrate the feasibility and capability of a dielectric barrier (DB) reactor to operate under direct current (DC) voltage, a condition made possible by the innovative use of a porous dielectric barrier (PDB). This unique configuration ensures the maintenance of the discharge without the risk of extinction, offering a significant advantage in terms of stability and energy efficiency. By operating under DC voltage, the reactor minimizes the risk of arcing, which enhances both the durability and safety of the system, making it highly suitable for industrial applications. Following this study, several promising research avenues could be explored to further enhance the performance and versatility of the PDB reactor operating under continuous voltage. First, it would be beneficial to investigate alternative dielectric materials for the PDB, focusing on optimizing thermal dissipation and extending the reactor's operational lifespan. Materials with higher thermal conductivity or tailored porosity could significantly improve heat management and overall efficiency. Additionally, a comparative study between the reactor's performance under DC and alternating current (AC) could provide valuable insights into its adaptability for various industrial applications. Such a study would help identify the specific conditions under which each operating mode is most effective, enabling tailored solutions for different use cases.

Finally, the integration of advanced thermal control systems, such as forced convection or liquid cooling, could further enhance the reactor's stability under prolonged operating conditions. These improvements would not only increase the reactor's reliability but also broaden its range of applications, particularly in high-power or continuous-use scenarios. By addressing these areas, future research could unlock the full potential of the PDB reactor, paving the way for more energy-efficient and cost-effective plasma technologies in industrial settings.

Acknowledgment

The authors of APELEC Laboratory, Djillali Liabès University of Sidi Bel-Abbès would like also to thank the General Directorate of Scientific Research and Technological Development (DGRSDT) in Algeria for their technical support and the specific research budget allocated to this program.

References

- [1] Nozaki T., Miyasaki Y., Unno Y., and Okasaki K., Energy distribution and heat transfer mechanisms in atmospheric pressure non-equilibrium plasmas, *J. Phys. D: Appl. Phys.*, Vol. 34 (23), pp. 3383–3390, 2001.
- [2] Jousot R., Boucinha V., Weber R., and Hong D., Negative spark leaders on a surface DBD plasma actuator, *IEEE Trans. Plasma Sci.*, Vol. 39 (11), pp. 2194–2195, 2011.

- [3] Yehia A., The thermal energy loss in the dielectric barrier discharge plasma, *Int. J. Plasma Environ. Sci. Technol.*, Vol. 18 (3), e03002, 2024.
- [4] Eid A., Takashima K., and Mizuno A., Experimental study of dielectric-barrier-discharge reactor for plasma-assisted-combustion, *Int. J. Plasma Environ. Sci. Technol.*, Vol. 9 (2), pp. 120–126, 2015.
- [5] Roth J. R., Sherman D. M., and Wilkinson S. P., Electro-hydrodynamic flow control with a glow-discharge surface plasma, *AIAA Journal*, Vol. 38 (7), pp. 1166–1172, 2000.
- [6] Boyko M.I., Makogon A.V., The micro- and nanosecond discharges in gas bubbles for water disinfection and purification, *Electr. Eng. Electromechanics*, pp. 50–54, 2019.
- [7] Getnet T. G., Kayama M E., Rangel E C., and Cruz N C., Thin film deposition by atmospheric pressure dielectric barrier discharges containing eugenol: discharge and coating characterizations, *Polymers*, Vol. 12, 2692, 2020.
- [8] Dhakal O. B., Dahal R., Acharya T.R., Lamichhane P., Gautam S., Lama B., Khanal R., Kaushik N K., Choi E H, and Chalise R., Effects of spark dielectric barrier discharge plasma on water sterilization and seed germination”, *Current Appl. Phys.*, Vol. 54, pp. 49–58, 2023.
- [9] Choudhury B., Portugal S., Roy S., Maestro E., and Johnson J.A., Smart dielectric barrier discharge plasma decontamination: spatially targeted decontamination with actuated ozone distribution, *Frontiers Phys.*, Vol. 10, 834030, 2022
- [10] Zhang C., Shao T., Yu Y., Niu Z., Yan P., and Zhou Y.X., Comparison of experiment and simulation on dielectric barrier discharge driven by 50 Hz AC power in atmospheric air, *J. Electrostat.*, Vol. 68, pp. 445–452, 2010.
- [11] Sharma S. K., and Sharma A., Sterilization of microorganisms contaminated surfaces and its treatment with dielectric barrier discharge plasma, *Trans. Indian National Academy Eng.*, Vol. 5, pp. 321–326, 2020.
- [12] Choi E.H., Uhm H.S., and Kaushik N.K., Plasma bioscience and its application to medicine, *AAPS Bulletin*, Vol. 31, 10, 2021.
- [13] Wagner H. E., Brandenburg R., Kozlov K., Sonnenfeld A., Michel P., and Behnke J.F., The barrier discharge: basic properties and applications to surface treatment. *Vacuum*, 71, pp. 417–436, 2003.
- [14] Boiko M. I., Makogon A.V., Features of distribution of electric field strength and current density in the reactor during treatment of liquid media with high-voltage pulse discharges, *Electr. Eng. Electromechanics*, No.5, pp. 58–63, 2024.
- [15] Korytchenko K.V., Bolyukh V.F., Buriakovskiy S.G., Kashansky Y.V., Kocherga O.I., Electromechanical and thermophysical processes in the pulse induction accelerator of plasma formation, *Electr. Eng. Electromechanics*, No.5, pp. 58–63, 2023.
- [16] Laroussi M., Special Issue on Low Temperature Plasma Jets, *Electrical & Computer Engineering Department*, Old Dominion University, Norfolk, VA 23529, USA, <https://doi.org/10.3390/plasma2030025>, 31 July 2019.
- [17] Vandani S A K., Farhadian L., Pennycuick A., Ji H F., Polymerization of sodium 4-styrenesulfonate inside filter paper via dielectric barrier discharge plasma, *Plasma*, Vol. 7 (4), pp. 867–876, 2024.
- [18] Moreau E., Airflow control by non-thermal plasma actuators, *Appl. Phys.*, Vol. 40, pp. 605–636, 2007.
- [19] Brandenburg R., Becker K.H., and Weltmann K.D., Barrier discharges in science and technology since 2003: A tribute and update, *Plasma Chem. Plasma Proc.*, Vol. 43, pp.1303–1334, 2023.
- [20] Hehner T., Gatti D., Kotsonis M., and Kriegseis J., Effects of actuation mode on plasma-induced spanwise flow oscillations, *J. Phys. D: Appl. Phys.*, Vol. 55 (20), 205203, 2022.
- [21] Gu J.G., Zhang Y., Gao M.X., Wang H.Y., Zhang Q.Z., Yi L., and Jiang W., Enhancement of surface discharge in catalyst pores in dielectric barrier discharges, *J. Appl. Phys.*, Vol. 125 (15), 153303, 2019.
- [22] Bénard N., Moreau E., EHD force and electric wind produced by plasma actuators used for airflow control, *6th AIAA Flow Control Conference*, paper AIAA-2012-3136, 2012.
- [23] Samoilescu G., Sotir A., Constantinescu M., and Solcanu V., The simulation of the electric discharges and the effects of the field on the electronic equipments and on the human factor on the ship, *Revue roumaine des sciences techniques, série électrotechnique et énergétique*, Vol. 53 (21), Suppl., pp. 179–189, 2008.
- [24] Sadat H., Conduction heat transfer in a cylindrical dielectric barrier discharge reactor, *Appl. Thermal Eng.*, Vol. 29, pp. 1259–1263, 2009.
- [25] Kim. H.H., Ayman A., Teramoto Y., Nozaki T., Kim D.Y., Brandenburg R., Schiorlin M., Hensel K., Song Y.H., Lee. D.H., Kang W.S., and Akira M., Revisiting why DBDs can generate O₃ against the thermodynamic limit, *Int. J. Plasma Environ. Sci. Technol.*, V17 (2), e02004, 2023.
- [26] Meyer C., Müller S., Gurevicha E. L., and Franzke J., Dielectric barrier discharges in analytical chemistry, *Anal.*, Vol. 136 (12), pp. 2427–2440, 2011.
- [27] Brandenburg R., Dielectric barrier discharges: progress on plasma sources and on the understanding of regimes and single filaments, *Plasma Sources Sci. Technol.*, Vol. 26 (5), 053001, 2017.